

B. GENERAL TESTS

Arsenic Limit Test

The Arsenic Limit Test is designed to determine the allowable limit of arsenic in a sample. The limit is expressed in terms of arsenic trioxide (As_2O_3).

Hereinafter in the Monographs, such a specification as "not more than $4.0 \mu\text{g/g}$ as As_2O_3 (0.25 g, Method 1, Apparatus A)" indicates that when determined as directed in the method using Apparatus A, using the test solution prepared by weighing 0.25 g of the test substance and proceeding as directed in Method 1, the arsenic content of the substance is not more than $4.0 \mu\text{g/g}$ as As_2O_3 .

Apparatus A Use the apparatus illustrated in Fig. 1.

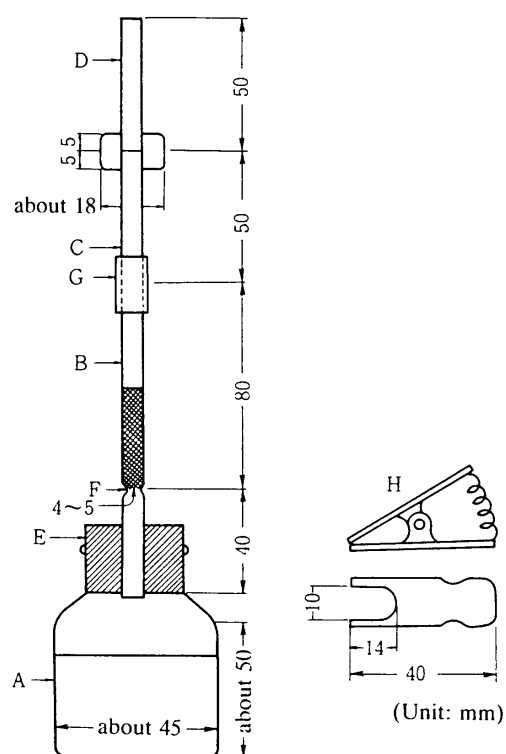

- A: Generator bottle (Capacity: about 60 ml, with a marked line indicating 40 ml)
- B: Glass tube with about 6.5 mm internal diameter
- C and D: Tube with a ground joint of 6.5 mm in internal diameter and about 18 mm in external diameter; both circles have the same center.
- E: Rubber stopper
- F: Dent at the lower part of glass tube B for supporting a plug of glass fiber
- G: Rubber tube
- H: Clip

Fig. 1

B. GENERAL TESTS

Stuff a plug of glass fiber into glass tube B about 30 mm in height from dent F, moisten the fiber uniformly with a mixture of an equal volume of lead acetate TS and water, then remove the excess of the solution from the glass fiber and the wall of the tube by gentle suction from the lower end of the tube.

Just before use, place a sheet of mercuric bromide test paper between the joint of glass tubes C and D, and fix both tubes with clip H.

Apparatus B Use the apparatus illustrated in Fig. 2.

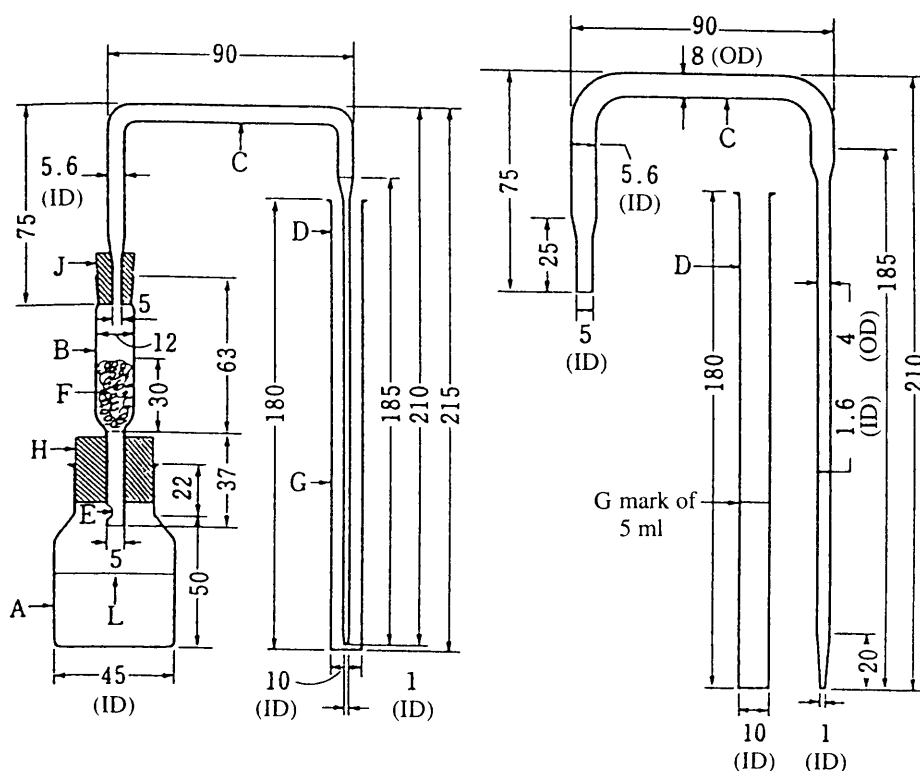

- A: Generator bottle (capacity up to the shoulder: approximately 70 ml).
- B: Exit tube.
- C: Glass tube (internal diameter: 5.6 mm, the tip of the part to be inserted in the absorber tube D is stretched out to 1 mm in diameter).
- D: Absorber tube (internal diameter: 10 mm).
- E: Small perforation
- F: Glass fiber (about 0.2 g).
- G: Mark of 5 ml.
- H and J: Rubber stoppers.
- L: Mark of 40 ml.

Fig.2

B. GENERAL TESTS

Stuff glass fiber F in exit tube B up to about 30 mm in height, moisten the glass fiber uniformly with a mixture of equal volumes of lead acetate TS and water, and gentle suction to the lower end to remove the excess of the mixture. Insert the tube vertically into the center of rubber stopper H, and attach the tube to generator bottle A so that small perforation E in the lower end of B extends slightly below. To the upper end of B, attach rubber stopper J to which tube C is vertically fitted. Make the lower end to the exit tube of C level with the lower end of rubber stopper J.

Apparatus C Use the apparatus illustrated in Fig. 3.

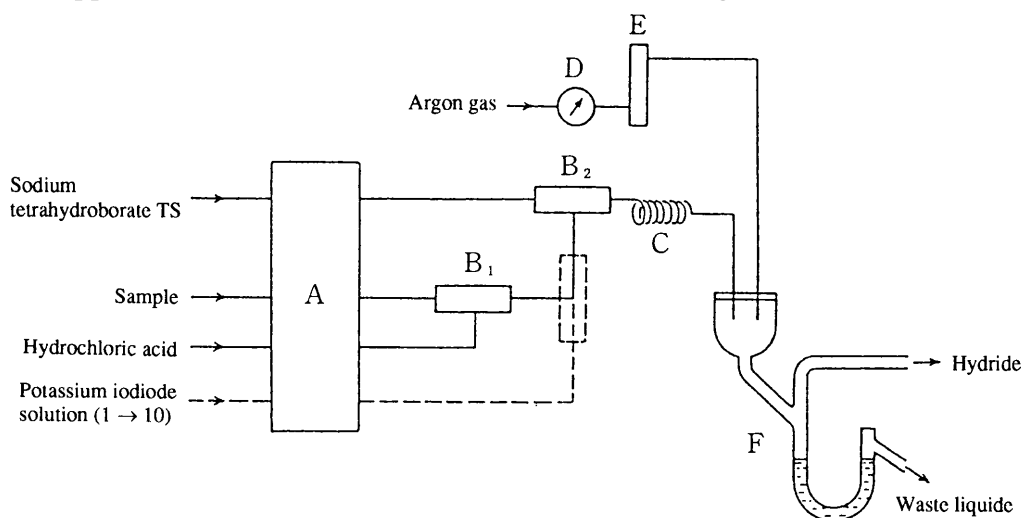

- A: Pump
- B₁, B₂: Mixing joint
- C: Reaction tube
- D: Pressure gauge
- E: Flow meter
- F: Gas-liquid separator

Fig. 3

Procedure (1) Preparation of Test Solution Unless otherwise specified, proceed by an appropriate one of the following methods.

Method 1 Weigh the specified amount of the sample, add 5 ml of water, dissolve by heating if necessary, and use the solution as the test solution.

Method 2 Weigh the specified amount of the sample, add 5 ml of water, and add 1 ml of sulfuric acid except that the samples are inorganic acids. Add 10 ml of sulfurous acid, transfer into a small beaker, and evaporate the mixture on a water bath until it becomes free from sulfurous acid and is reduced to about 2 ml. Dilute with water to make 5 ml, and use it as the test solution.

Method 3 Weigh the specified amount of the sample, and place it in a crucible

B. GENERAL TESTS

of platinum, quartz, or porcelain. Add 10 ml of a solution of magnesium nitrate in ethanol (1 : 50), ignite ethanol, and heat gradually at 450 to 550 to incinerate. If the carbonized material still remains, moisten with a small quantity of a solution of magnesium nitrate in ethanol (1 : 50), and ignite again at 450 - 550 to incinerate. After cooling, add 3 ml of hydrochloric acid, heat on a water bath to dissolve the residue, and use it as the test solution.

Method 4 Weigh the specified amount of the sample, and place it in a crucible of platinum, quartz, or porcelain. Add 10 ml of a solution of magnesium nitrate in ethanol (1 : 10), ignite ethanol, and heat gradually at 450 - 550 to incinerate. If the carbonized material still remains, moisten with a small quantity of a solution of magnesium nitrate in ethanol (1 : 50), and ignite again at 450 - 550 to incinerate. After cooling, add 3 ml of hydrochloric acid, heat on a water bath to dissolve the residue, and use it as the test solution.

(2) Test Unless otherwise specified, proceed by any of the following methods.

(i) *Method using Apparatus A*

Transfer the test solution into the generator bottle, add 1 drop of bromophenol blue TS, neutralize with aqueous ammonia, ammonia TS, or diluted hydrochloric acid (1 : 4), add 5 ml of diluted hydrochloric acid (1 : 2) and 5 ml of potassium iodide TS, and allow to stand for 2 to 3 minutes. Add 5 ml of acidic stannous chloride TS, and allow to stand for 10 minutes. Then, add water to make 40 ml, add 2 g of arsenic-free zinc, immediately place rubber stopper E attached to glass tubes B, C, and D, then immerse the generator bottle up to the shoulder in water at a temperature of 25 °C, and allow to stand for 1 hour. Immediately observe the color of the mercuric bromide test paper. The color of the paper is not deeper than the following standard color.

Preparation of Standard Color is carried out at the same time as the test of test solution. Unless otherwise specified, measure 1.0 ml of Arsenic Standard Solution, transfer into a generator bottle, and add 5 ml of diluted hydrochloric acid (1 : 2) and 5 ml of potassium iodide TS. Proceed in the same manner as the test solution, and use the color produced by the mercuric bromide test paper as the standard color.

(ii) *Method using Apparatus B*

Transfer the test solution into the generator bottle, proceed as directed for the method using Apparatus A, add 5 ml of acidic stannous chloride TS, and allow to stand for 10 minutes. Then add water to make 40 ml, add 2 g of arsenic-free zinc, and immediately connect the rubber stopper H, fitted with B and C, with generator bottle A. Insert the tip of C to the bottom of absorber tube D containing 5 ml of the absorbing solution for arsenic hydride, then immerse the generator bottle A up to the shoulder in water maintained at 25 °C, and allow to stand for 1 hour. Disconnect the absorber tube, add pyridine to make 5 ml, if necessary, and observe the color of the absorbing solution.

B. GENERAL TESTS

The color produced is not deeper than the standard color. Preparation of Standard Color is carried out at the same time as the test of test solution. Measure 2.0 ml of Arsenic Standard Solution, transfer into a generator bottle, add 5 ml of diluted hydrochloric acid (1 : 2) and 5 ml of potassium iodide TS, allow to stand for 2 to 3 minutes. Add 5 ml of acidic stannous chloride TS, allow to stand at room temperature for 10 minutes. Proceed in the same manner as the test solution, use the color produced by the absorbing solution as the standard color.

(iii) *Method using Apparatus C*

To 4 ml of the test solution, add 1 ml of hydrochloric acid and 1 ml of potassium iodide solution (1 : 10), heat on a water bath at 70 °C for 4 minutes, and add water to make 20 ml. Flowing argon gas through the apparatus, introduce the test sample, an appropriate concentration of hydrochloric acid (1 - 6 mol/l), and sodium tetrahydroborate TS into the apparatus continuously at flow rate of 1-10 ml/min with pump A and mix successively in the apparatus to form arsenic hydride. the method that potassium iodide solution (1 : 10) is also introduced continuously into the apparatus, introduce the test solution (if necessary, after dilution with water), an appropriate concentration of hydrochloric acid (1 - 6 mol/l), potassium iodide solution (1 : 10), and sodium tetrahydroborate TS successively into the apparatus in the same procedure as described above. Arsenic hydride formed is separated from the waste liquid by gas-liquid separator F, and gas containing arsenic hydride is introduced into an atomic absorption spectrophotometer (flame type) equipped with an absorption cell. Measure the atomic absorbance of the test solution at 193.7 nm. The absorbance of the test solution does not exceed that of the following control solution.

Preparation of the control solution is carried out at the same time as the test of test solution. Prepare the control solution in the same manner as for the test solution, using the specified Arsenic Standard Solution.

Notice on Procedure (1) Apparatus, reagents, and test solutions used in the test should contain little or no arsenic and, if necessary, perform a blank test.

(2) Connect tightly the ground joints holding the mercuric bromide test paper so that the gas produced does not leak out.

(3) As the color of the mercuric bromide test paper fades under light, heat, or moisture, the comparison of colors should be performed immediately. The colored test papers can be preserved for a while by keeping them in a desiccator, protecting from light.

(4) In the case that Apparatus C is used, the flow rates of a hydrochloric acid solution, sodium tetrahydroborate TS, and a potassium iodide solution, and the concentrations of a hydrochloric acid solution and a potassium iodide solution are dependent on the apparatus used. Furthermore, a sodium tetrahydroborate solution whose concentration is different from sodium tetrahydroborate TS may be used.